

LASER

Anodized Aluminum

The Laser is an anodized aluminum enclosure with a 1 3/4" frame that protrudes only 3/8" from the face of the fireplace. It is available as a combination overlap, inside fit.

STANDARD FINISHES – Black, Polished Brass Finish.	
Optional Glass Channel/ Handle Finishes –	Stainless, Antique, or Chrome
Door Styles –	Available with CV2 bi-fold tracked doors or FS2 bi-fold full swing trackless doors
Standard Glass –	1/4" tempered bronze, clear or grey colored glass with lifetime warranty
Glass Options –	Beveled Glass Mirrored Glass: Bronze
OPTIONS	
Mesh Options –	Heavy 19 gauge mesh curtain, 1/8" flattened expanded steel, 25 gauge mesh door



Shown in Grey Iron.

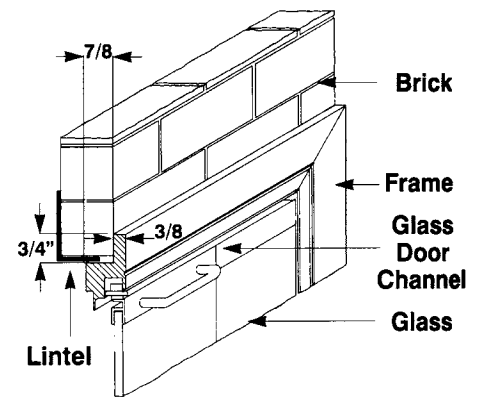

SIZING CHART FOR THE LASER

FINISH	MODEL NO.	DOOR STYLE	GLASS	OVERALL FRAME SIZES
Black Polished Brass	Laser	CV2: Bi-fold tracked door FS2: Bi-fold full swing trackless door	Bronze, Clear or Grey	Up to 44" wide by 31" high Up to 50" wide by 39" high For larger sizes and frame widths, contact factory for quote.
OPTIONAL FINISHES:				
BZ – Bronze Iron CU – Copper FTB – Fine Textured Brown GAV – Gold Antique Vein GI – Grey Iron MI – Moss Iron NI – Natural Iron NRST – New Rust OCPR – Old Copper OI – Old Iron SAV – Silver Antique Vein TB – Fine Textured Black TCH – Textured Chestnut TR – Textured Rust				

HOW TO ORDER

Use custom order form #1 in the separate Price List and completely fill out all information requested.
• Order must be mailed or faxed to Thermo-Rite.